

VENTILATION CABLE GLAND

DAK 284 | IP66 / IP67



- > Cable gland with integrated ventilation
- > High degree of protection
- > Easy to install
- > Integrated strain relief
- > Waterproof filter
- > Large clamping range

Pressure differentials in enclosures with a high degree of protection are a result of internal and external temperature changes. In the case of negative pressure or partial vacuum, dust and humidity can enter the enclosure through the door seal. When the air inside the enclosure cools down, condensation may occur because the humidity cannot escape the enclosure. The innovative and easy-to-install ventilation cable gland DAK 284 enables secure cable entry into an enclosure with simultaneous pressure compensation (protection type IP66 / IP67). Even with a slight overpressure, a waterproof filter inside the gland allows the humidity to escape whilst blocking water and dirt from entering the enclosure.



TECHNICAL DATA

Mounting	thread M12 x 1.5 / M16 x 1.5 / M20 x 1.5
Enclosure wall thickness	0.02 – 0.12" (0.5 – 3 mm) with lock nut
Material	plastic, light grey
Protection type	IP66 / IP67 (EN 60529)
Sealing	sealing gasket NBR
Filter	PTFE
Fitting position	variable
Operating/Storage temperature	-4 to +176 °F (-20 to +80 °C)
Approvals	VDE, UL File No. E471430, EAC

Installation: Make hole cut-out in enclosure and secure ventilation cable gland with lock nut. Please make sure that the sealing gasket is put in place on the exterior side panel of the enclosure and the hole is free of burrs.

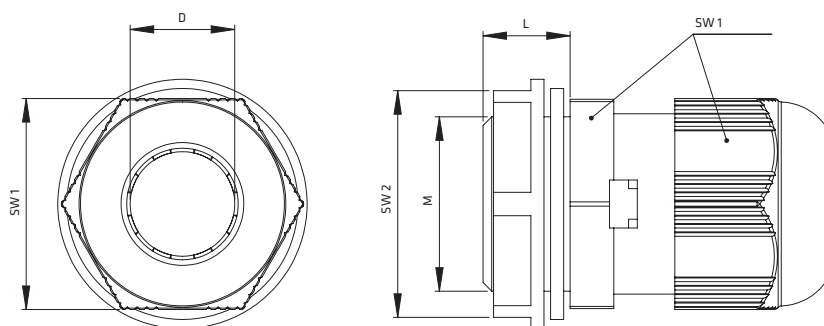

Part No.	Thread		External thread diameter	Cable dia. clamping range D	Hex nut dia.		Torque		Air permeability ¹	Weight
	Size M [mm]	Length L			SW 1	SW 2	Lock nut	Dome nut		
28410.0-00	M12 x 1.5	0.31" (8 mm)	0.48" (12.3 mm)	0.16 – 0.32" (4 – 8 mm)	0.74" (19 mm)	0.71" (18 mm)	2 Nm	2 Nm	25 l/h	0.25 oz. (7 g)
28411.0-00	M16 x 1.5	0.39" (10 mm)	0.64" (16.3 mm)	0.16 – 0.32" (4 – 8 mm)	0.74" (19 mm)	0.86" (22 mm)	2 Nm	2 Nm	25 l/h	0.28 oz. (8 g)
28412.0-00	M20 x 1.5	0.39" (10 mm)	0.8" (20.3 mm)	0.24 – 0.48" (6 – 12 mm)	0.94" (24 mm)	1.02" (26 mm)	5 Nm	5 Nm	40 l/h	0.46 oz. (13 g)

¹ at a pressure differential of 70 mbar (1 psi)